



D03 FluidDyne Valves

- 4 Way, 2 and 3 Position Solenoid Operated
- Variety of Voltage and Spool Configurations
- Same Day Shipments
- 18 Month Warranty



DO3 Fluidyne Valves:

4 Way, 2 and 3 position solenoid operated directional D03 valves with a variety of voltage and spool configurations.

- Flow Rate 14 gpm
- 310 bar / 4500 psi
- 100 bar / 1450 psi tank port pressure
- Endurance tested to 10 million cycles
- 18 month warranty
- Cost effective replacement to Rexroth, Bosch, Vickers and Parker with superior performance
- Large inventory allows same day shipment

Features & Benefits:

WFDG4V-3S (D03) Standard Performance Models:

- Up to 60 l/min. (15 US gpm) respectively at 310 bar (4500 psi)
- International standard interface. The valve mounting face conforms to ISO 4401, size 03 and is compatible with related international standards.

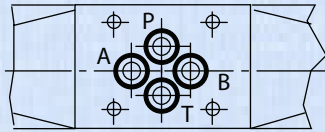

Mounting surface to ISO 4401 size 3

- Ease of Servicing
Wet-armature solenoid, screw in core tube design allows coils to be changed without removing valve from installation and without oil spillage or risk of contamination system fluid.

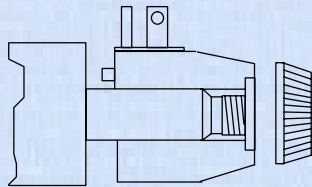

ISO4400 (DIN 43650) coil shown

- Electrical Connections
Conduit box and DIN connection designs simplify electrical wiring connections to solenoids. Orientation tabs prevent incorrect positioning.

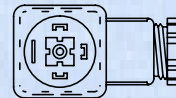
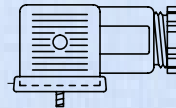
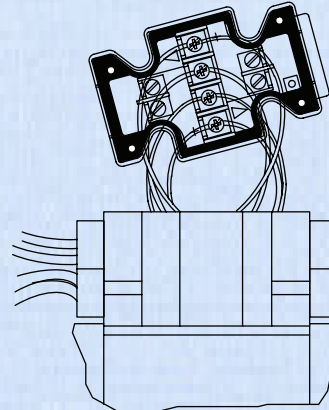

Model Code Breakdown

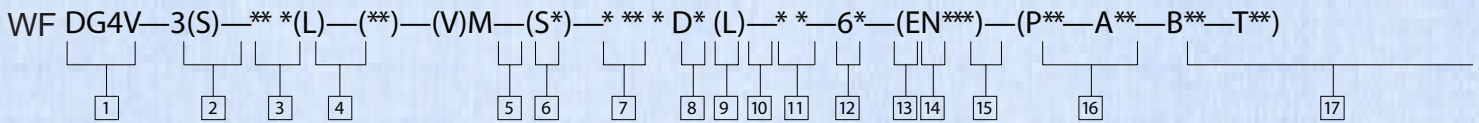

1 Model Series
 D – Directional valve
 G – Subplate/manifold mounted
 4 – Solenoid operated
 V – Pressure rating 350 bar (5075 psi) on P, A & B ports

2 Standard or high performance
 3* – High performance specification: up to 80 l/min (21 USgpm) at 350 bar (5075 psi)
 3S – Standard performance specification: up to 40 l/min (10.5 USgpm) at 350 bar (5075 psi)

3 Spool type
 See page 4.

4 Spool Spring Arrangement
 A – Spring offset, end-to-end
 AL – Same as “A” but left hand build
 B – Spring offset, end to center
 BL – Same as “B” but left hand build
 C – Spring centered
 N* – No-spring detented

5 Solenoid energization identity
 V – Solenoid “A” is at port “A” end and/ or solenoid “B” is at port “B” end, independent of spool type
 Omit for U.S. ANSI B93.9 standard requiring solenoid “A” energization to connect P to A and/or solenoid “B” to connect P to B, independent of solenoid location.
 NOTE: Type “8” spool valves conform to both U.S. and European solenoid designs. When ordering an “8” spool, designate a “V” in the model code.

6 Flag symbol
 M – Electrical options and features

7 Spool indicator switch*
 Available on high performance models, DG4V-3, only. Omit when not required.

8 Coil type
 U – ISO 4400 (DIN 43650) mounting
 U1 – Connector fitted
 U6 – Connector fitted w/lights
 U11 – Connector fitted w/rectifier & lights
 U12 – Connector fitted w/rectifier
 F – 1/2" NPT thread conduit box

9 Electrical connector
 T – Wired terminal block
 PA – Instaplug male receptacle only
 PB* – Instaplug male & female receptacle
 PA3* – Three pin connector
 PA5 – Five pin connector

10 Housing (F type coils only)
 W – 1/2" NPT thread wiring housing

11 Surge suppressor/damper
 D1 – Encapsulated diode (Industrial applications)
 D2 – Encapsulated diode (Mobile applications)
 D7 – Transorb type (U only)

12 Solenoid indicator lights
 L available on U, U1, U6, W

13 Coil rating
 Full power coils, see “Operating Data.”
 A – 110V AC 50Hz
 B ◊ – 110V AC 50Hz/120V AC 60 Hz
 D ◊ – 220V AC 50 Hz/240V AC 60 Hz
 G – 12V DC
 H – 24V DC

◊ For 60 Hz or dual frequency

14 Port T code
 Refer to “Operating Data” for port T pressure ratings.
 5 – 100 bar (1500 psi) for standard performance models, DG4V-3S, with AC or DC solenoids.
 6 – 207 bar (3000 psi) for AC high performance models, DG4V-3, including spool position indicator type S6.
 7 – 207 bar (3000 psi) for DC high performance models, DG4V-3, including spool position indicator type S6.

16 Special features
 “EN*****” code number assigned as required.
 EN21* – CSA approved models with 1/2" NPT entry conduit box, type FW and solenoid coil letter B, D, G, or H.

17 Port restrictor plugs
 For details of plug orifice sizes and how to specify in model code. Maybe fitted to valves by agreement with your FluiDyne representative.
 Omit – No restrictor plugs fitted

15 Design number
 60 – Basic design
 61 – Type 8 spool

Contact our customer service department for additional coil and spool options!

* Reman only!



Characteristics

WFDG4V-3S models are direct solenoid operated directional control valves. Their primary function in a hydraulic circuit is to direct fluid flow. This, in turn, would determine the direction of movement of a fluid cylinder, or the direction of rotation of a fluid motor.

Port connections are made by mounting the valve on a subplate or manifold. The valve has wet armature type solenoids.

Electrical connections to the valve are made in the electrical wiring housing or through various plug-in connectors such as a DIN 43650 type coil.

Good hydraulic design practice suggests that detented models be mounted with longitudinal axis horizontal. Other models may be mounted in any position.

Construction of a typical single solenoid model.

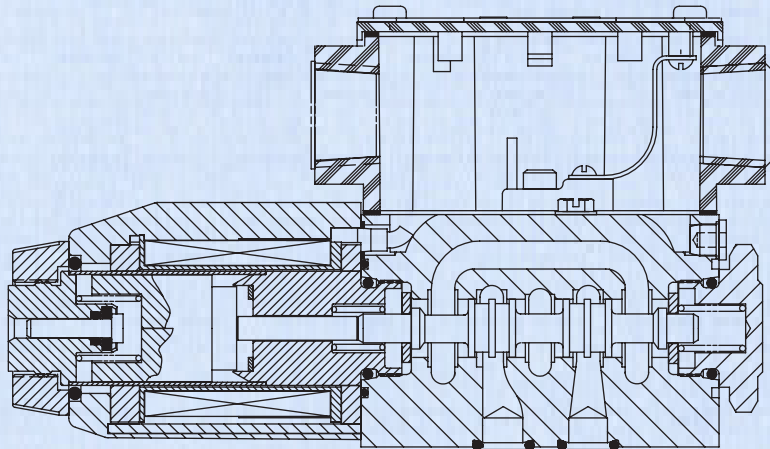

Our people provide extensive support:

- Engineering Expertise
- Decoding special part numbers
- Identification of parts within units
- Advice on component repair and assembly
- Component failure analysis
- Large local stock
- New application component selection
- Same day shipment
- 18 month warranty



Call us today to find out what makes us so great! (586) 296-7200

Functional Symbols

Solenoids identified to U.S. standards

Functional symbols related to solenoid identity "A" and/or "B" according to NFPA/ANSI standards, ex. energizing solenoid "A" gives flow P to A, solenoid "B" gives flow P to B (as applicable).

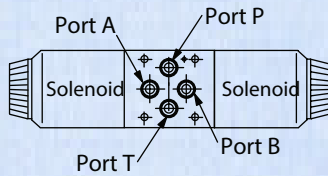

SOLENOID	FOR SPOOL TYPE	SOLENOID
B	All	A
	except "8"	
A	"8" only	B

For valves with type "8" spools, solenoid identity to U.S. convention is the same as for European convention.

Solenoids identified to European standards (specify "V" in model code)

Functional symbols related to solenoid identity "A" and/or "B" according to European convention ex. solenoid "A" adjacent to "A" port, solenoid "B" adjacent to "B" port of valve.

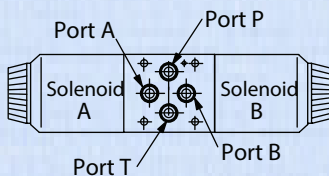

- For difference in valve function, refer to performance data.
- F Build Spools*

U.S. Solenoid Standard

Double solenoid valves, two position, detented

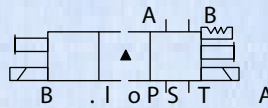

Double solenoid valves, spring centered

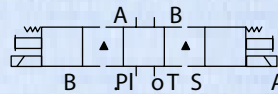

s Transient condition only

Single solenoid valves, solenoid at port A end

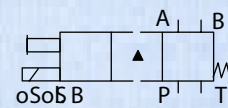

Single solenoid valves, solenoid at port B end

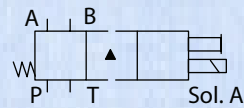

The valve function schematics apply to both U.S. and European Valves

DG4V-3(S)-*N(V)



DG4V-3(S)-*A(V)



DG4V-3(S)-*AL(V)

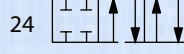
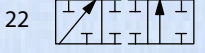
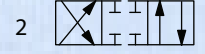

DG4V-3(S)-*C(V)



DG4V-3(S)-*B/F(V)



DG4V-3(S)-*BL/FL(V)

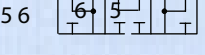
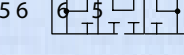
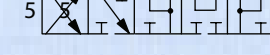
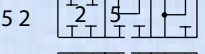
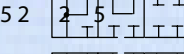
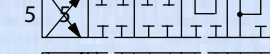
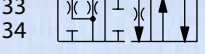
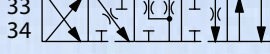
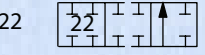
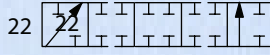
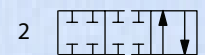

DG4V-3(S)-8C(V)

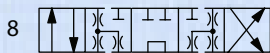

DG4V-3(S)-8BL(V)

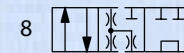

DG4V-3(S)-8B(V)

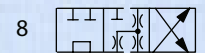

European Solenoid Standard (V)

Double solenoid valves, two position, detented

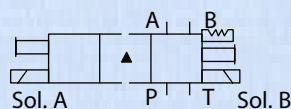

Single solenoid valves, solenoid at port A end

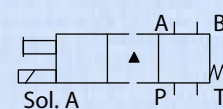

Single solenoid valves, solenoid at port B end

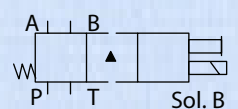

Double solenoid valves, spring centered

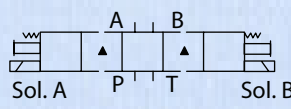

s Transient condition only



Operating Data

D03 Fluidyne Valves

Performance data is typical with fluid at 36cSt (168 SUS) and 50°C (122°F).

FEATURE	STANDARD PERFORMANCE VALVE WFDG4V3S	
Pressure Limits		
P, A and B ports	310 bar (4500 psi)	
T port:	100 bar (1450 psi)	
<hr/>		
Flow rating	See performance data	
Relative duty factor	Continuous; ED = 100%	
<hr/>		
Type of protection:		
ISO 4400 coils with plug fitted correctly	IEC 144 class IP65	
Coil winding	Class H	
Lead wires (coils type F***)	Class H	
Coil encapsulation	Class F	
<hr/>		
Permissible voltage fluctuation:		
Maximum	Refer to temperature limits.	
Minimum	90% rated	
<hr/>		
Typical response times at 100% rated volts measured from application/removal of voltage to full spool displacement of "2C" spool at:		
Flow rate P-A, B-T	20 l/min (5.3 USgpm)	
Pressure	175 bar (2537 psi)	
AC (~) energizing	18 ms	
AC (~) de-energizing	32 ms	
DC (=) energizing	60 ms	
DC (=) de-energizing	40 ms	
<hr/>		
Power consumption, AC solenoids (for coils listed in model code).	Initial s VA (RMS)	Holding VA (RMS)
<hr/>		
Full power coils:		
Dual frequency coils at 50 Hz	265	49
Dual frequency coils at 60 HZ	260	48
<hr/>		
Power consumption, DC solenoids at rated voltage and 20 C (68 F).		
Full power coils:		
12V, model type "G"	30W	-
24V, model type "H"	30W	-

Performance Data

WF DG4V3S Models

Graph 1
AC solenoid valves with:
- Single-frequency coils
- Dual-frequency coils operating at 50 Hz

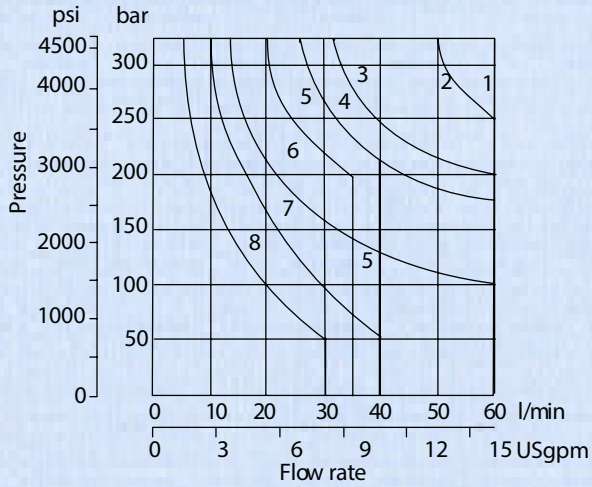

Graph 2
AC solenoid valves with dual-frequency coils operating at 60 Hz

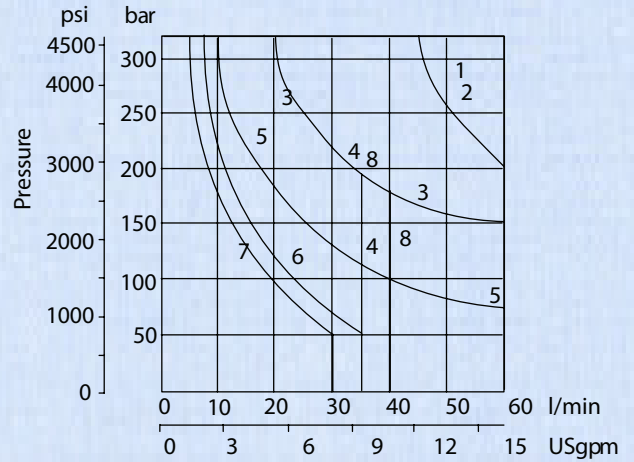

Graph 3
DC solenoid valves

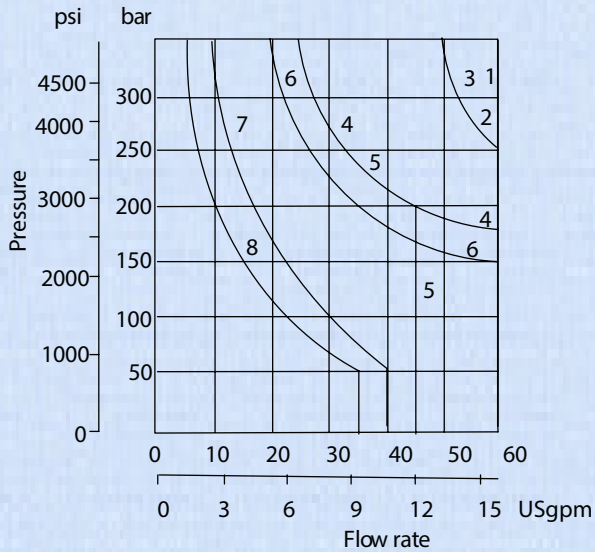

Spool/spring code	Graph 1 curve	Graph 2 curve	Graph 3 curve
0A(L)	2	2	3
0B(L) & 0C, 0F	1	1	2
2A(L)	2	2	3
2B(L) & 2C, 2F	1	1	1
2N	1	1	2
6B(L) & 6C, 6F	6	5	6
7B(L) & 7C, 7F	1	1	2
8B(L) & 8C	5	4	5
22A(L)	8	7	8
22B(L) & 22C	7	6	7

Installation Dimensions

Models for use with ISO 4400 (DIN 43650) connectors

Double solenoid models

WFDG4V-3(S)-*C-**-*(V)M-U-**-60

Single solenoid models

WFDG4V-3(S)-*A(-**)

WFDG4V-3(S)-*B(-**)

WFDG4V-3(S)-8BL(-**)

As shown

WFDG4V-3(S)-*AL(-**)

WFDG4V-3(S)-*BL(-**)

WFDG4V-3(S)-8B(-**)

Spolenoid and end cap interchanged

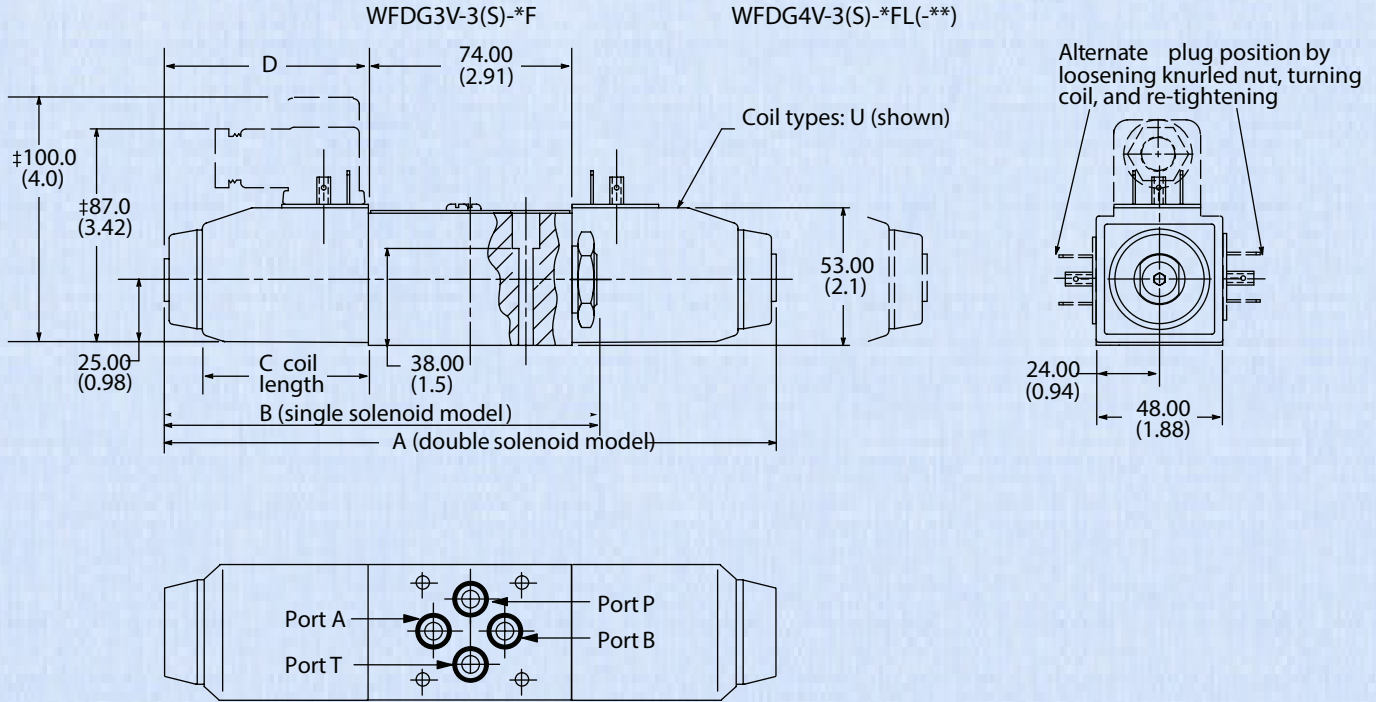

Dimensions in Inches.

AC or DC	A Dim.	B Dim.	C Dim.	D Dim.
DC	8.66	6.14	2.5	2.87
AC	7.87	5.75	1.7	2.48

Installation Dimensions

Models with "F" type coils (lead wires) and conduit box.

Double solenoid models
WFDG4V-3(S)-*C-**-*(V)M- F-**- 60

Single solenoid models
WFDG4V-3(S)-*A(-**)
WFDG4V-3(S)-*B(-**)
WFDG4V-3(S)-8BL(-**)
WFDG3V-3(S)-*F

As shown

WFDG4V-3(S)-*AL(-**)
WFDG4V-3(S)-*BL(-**)
WFDG4V-3(S)-8B(-**)
WFDG4V-3(S)-*FL(-**)

Solenoid and end cap interchanged

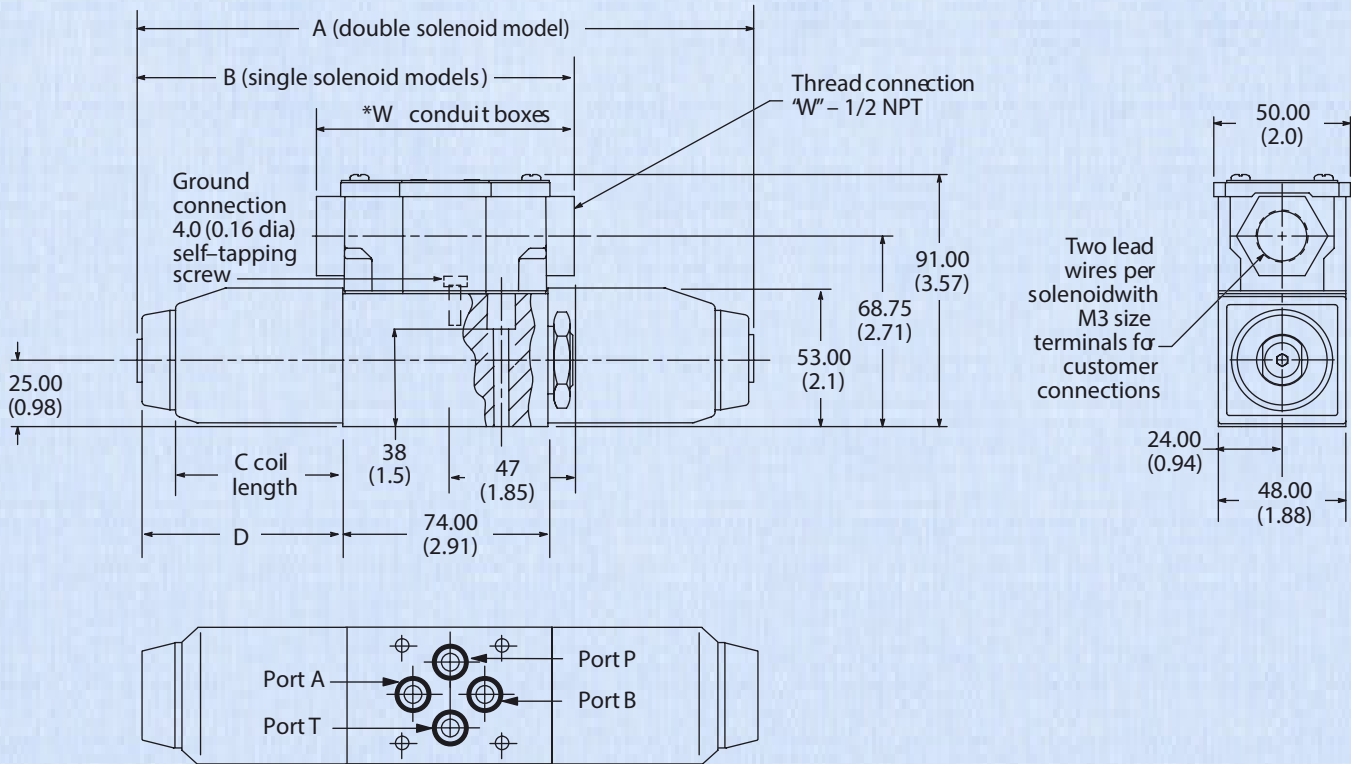

AC or DC	A Dim.	B Dim.	C Dim.	D Dim.
DC	8.66	6.14	2.5	2.87
AC	7.87	5.75	1.7	2.48

Dimensions in Inches.

I Not applicable to type "8" spool.

Code "FW": 2 lead wires for each solenoid, approximately 150.00 (6.0) long. M3 (#6) terminals provided for customer connection.

Code "FTW": Valve supplied with lead wires connected into terminal strip suitable for M3 (#6) terminals for customer connection.



Electrical Plugs & Connectors

Terminal Strip and Lights for Valves with Type "F" Coils

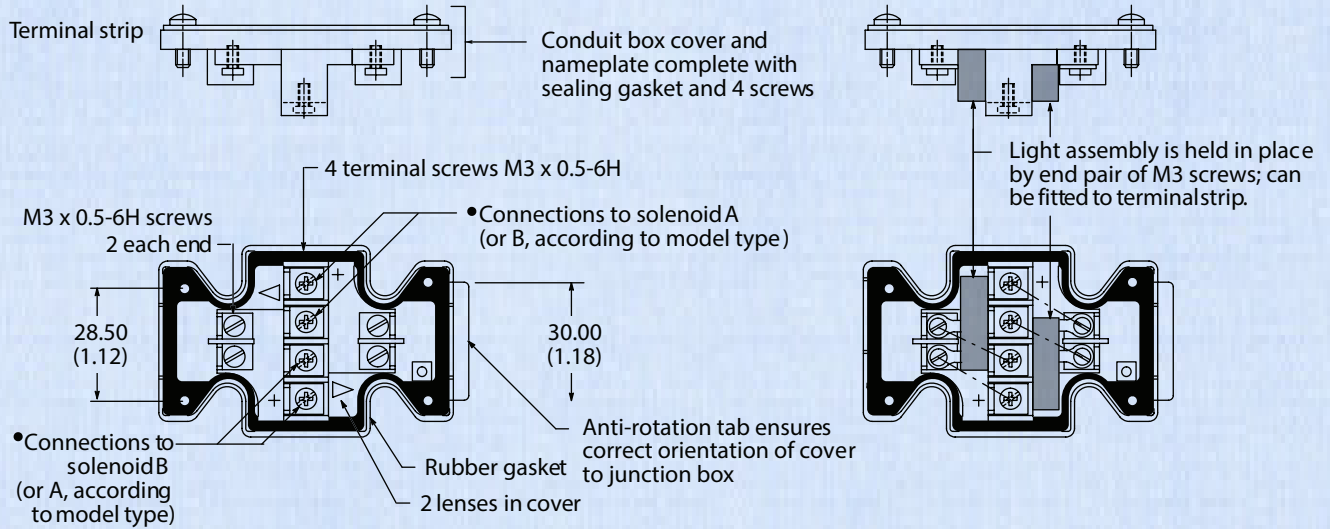

1. For DC coils the negative lead(s) must be connected to the terminal(s) marked +. When using 3-wire incoming leads to double solenoid valves (ex. common neutral) the inner pair of terminals must be interconnected.
2. For correct light indication of energized solenoid ensure that solenoid leads are correctly connected: light terminals are common with each outer pair of solenoid terminals according to the side with + mark.

DIN 43650 Connector

Cable diameter range: \varnothing 6-10 mm (0.24-0.40)

Wire section range: \varnothing 5-1.5 mm² (0.0008-0.0023 in²)

Terminals: Screw Type

Type of protection: IEC144 class IP65, when plugs are fitted correctly to the valves with interface seals (supplied with plugs) in place.

Connector can be positioned at 90° intervals on valve by re-assembling contact holder into appropriate position inside connector housing.

AC DC with Surge Protector bipolar LED and varistor drop-off delay app 3ms. The energy in the coil is restricted by the varistor.

Rectacle	Voltage (AC or DC)
Coils with lights	12-24 100-125 200-240
Rectified coils with lights	12 DC 24 DC 98-240 VDC 200-240 VDC

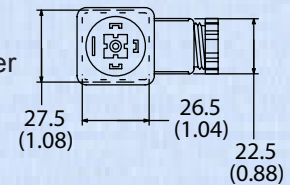
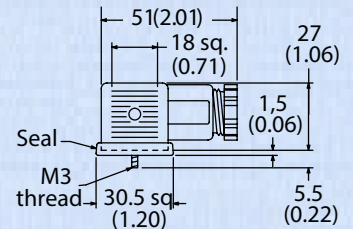

AC/DC with Rect. & Surge bridge rectifier and varistor drop-off delay app 3ms operating current max. 1.5A

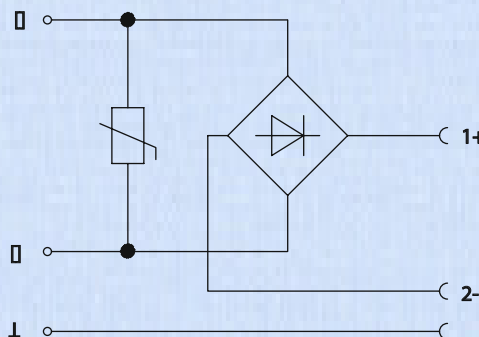
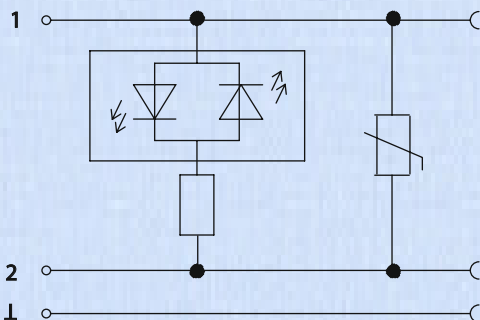

Installation Dimensions

Mounting Surface

When a subplate is not used, a machined pad must be provided for mounting. The pad must be flat within 0.01 mm per 100 mm (0.0001" per 1") and smooth within 0.8 µm.

The interface conforms to ISO 4401-AB-03-4A (size O3) plus location pin hole. ANSI/B93.7M (and NFPA) size O3 CETOP R35H4.2-03, plus location pin hole. DIN 24340 Form A6, plus location pin hole.

Dimensional tolerance = ± 0.2 (0.008) except where otherwise stated.

Prior to installing a valve, ensure that both valve and mounting surface are clean and free from burrs.

ISO 4401 gives dimensions in mm. Inch conversions are accurate to 0.01" unless stated.
#10-24 UNC-2B is optional.

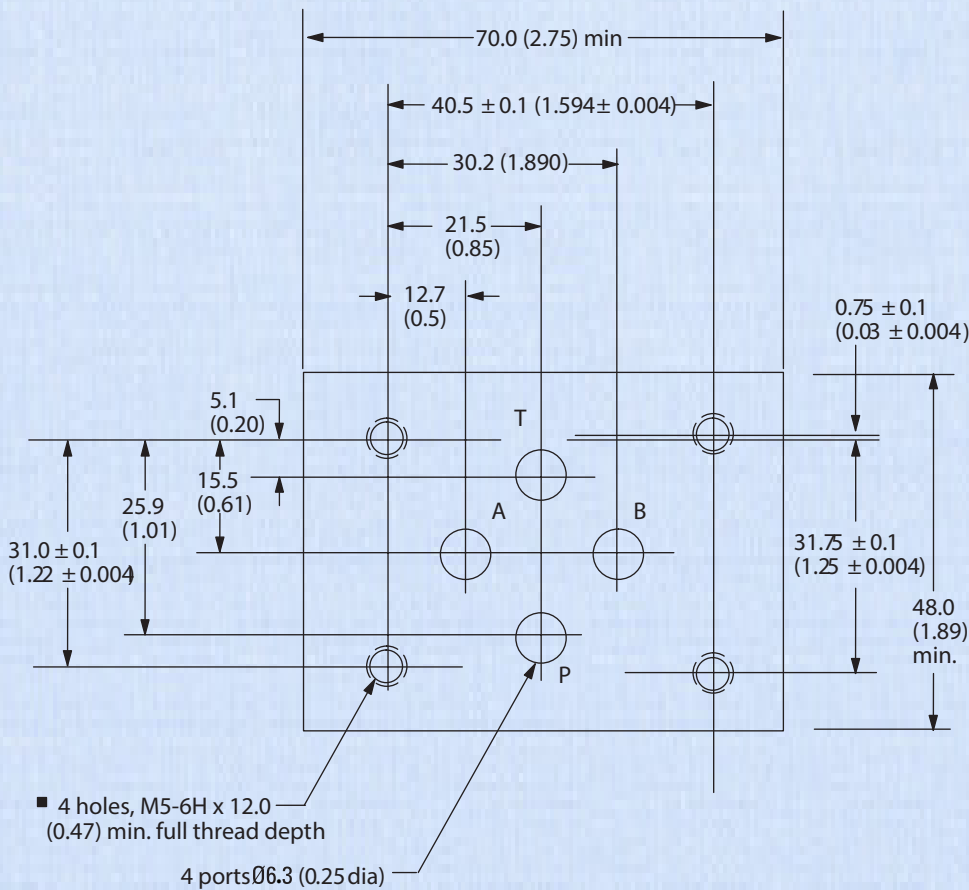

Mass, Approx. kg (lb)

	"U"	"F"
WFDG4V-3S (DC) coils		
Single sol. valve	1.6 (3.5)	1.8 (4.0)
Double sol. valve	2.2 (4.8)	2.3 (5.0)
WFDG4V-3S (AC) coils		
Single sol. valve	1.5 (3.3)	1.6 (3.5)
Double sol. valve	1.8 (4.0)	2.0 (4.4)



31915 Groesbeck Highway • Fraser, Michigan 48026

PH: 1-586-296-7200 • FAX: 1-586-296-7210

Email: sales@FluidyneFP.com

www.FluidyneFP.com

